

## Getting Started

Careful planning of the finished deck layout will result in better looking finished projects. Failure to follow installation guidelines could void warranty.

1. Joist location plays an important role in the safety of the deck itself but may also affect the ease, method and price of your railing system.
2. Before starting, read the instructions of both the decking and railing systems planned for the project.
3. Remember that prefabricated rail systems often assemble faster than wood railing but they are less flexible and do not assemble in the same way as wood rail systems. To enjoy the maximum benefit of prefabricated rail systems, it is important to construct the deck framing with the specific rail system in mind.
4. Thoroughly reading all instructions first will make for more profitable projects. Failure to do so may result in more difficult installation and may void warranty.

## Joists

Joists used in deck frame construction should be 2"x 8" or larger.

When installing deck boards perpendicular to the joists in residential applications, spacing is 16" on-center (Figure a). When the decking is to be laid diagonally, reduce the on center joist spacing by 4" (Figure b). For stair treads, follow local approved building codes. Stair stringers should not exceed 9" on center. Allow 1/8" space between stair treads and risers. Leave 3/16" space between stair treads. For special situations, or when in doubt, consult your local building inspection department.

When installing heavy loads atop your decking project, a hot tub, for example, it is important to also understand the requirements of the manufacturer as they may have specific framing and support requirements for their warranty coverage.

### Residential Joist Spacing

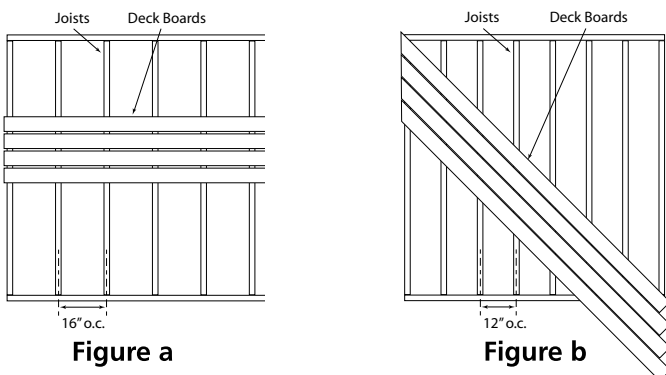

When installing blocking for more intricate decking patterns, remember that solid blocking (blocking laid on the flat) will inhibit water flow and result in buildup of organic materials over time, which will make cleaning more difficult. For best results when blocking is required, it should be installed ladder style (Figure c).

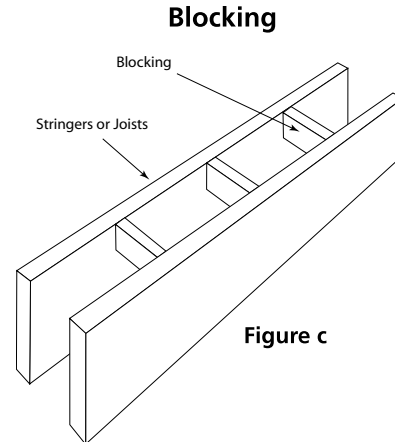

## Board Spacing

All decking materials, whether wood, composite or metal, undergo some degree of linear expansion with the changes of weather and the season. To compensate for the effects of contraction and expansion, the following installation standards must be maintained:

- 3/16" side to side spacing between the boards (Figure d)
- 1/4" gap between the deck board and any solid structure such as a wall or post (Figure d)
- Between board ends: 3/16" below 45° F (7° C), 1/8" 45° - 85° F (7° - 29° C), 1/16" over 85° F (29° C) (Figure e)

Adhering to these spacing parameters will:

- Promote proper drainage and ventilation
- Aid in the removal of organic debris
- Meet board spacing requirements for Veranda TD warranty coverage

### Side-To-Side Spacing

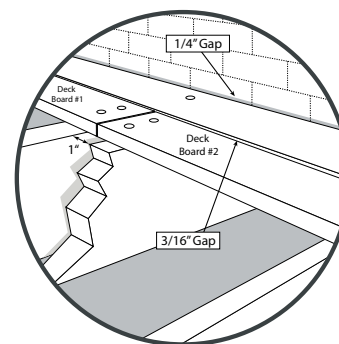

Figure d

### End Gapping

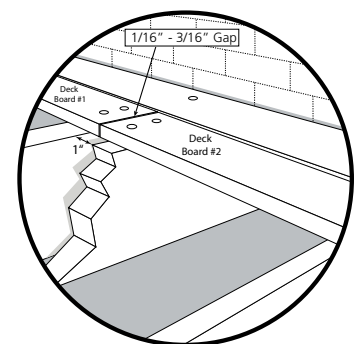

Figure e

### Fastener Setback

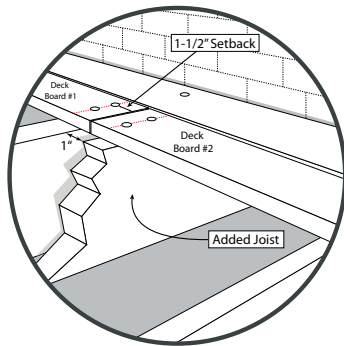

Figure f

### Surface Fasteners

Use Veranda ArmorGuard™ Fasteners, Stainless Steel Deck Screws or approved coated fasteners to prevent possible discoloration of decking. Galvanized surface fasteners should not be used. Pre-drilling is recommended. Screw heads must be flush with board surface. Caution must be used to avoid over-tightening fasteners. Excess tightening may cause immediate or eventual cracking of the board end.

### Requirements

Do not surface fasten within 1-1/2" of the end of a board or 1" from the side of the board. It is necessary to pre-drill end of board screw holes to prevent immediate or eventual end splitting (Figure f). Pre-drilling all holes, which will add time to the project, is not necessary, but it will result in better looking finished projects. DO NOT over-tighten fasteners. Over-tightening will induce cracking at board ends.

Surface Fasteners should always be driven in at a 90° angle to the decking surface. Toe nailing/screwing is not recommended (Figure g). Instead, the placement of an additional joist, when needed, is recommended to allow perpendicular installation of surface fasteners at board ends (Figure h). Pre-drilling is required in cold temperatures.

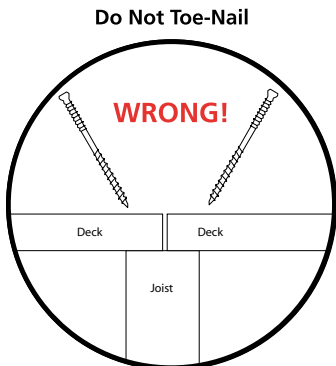

Figure g

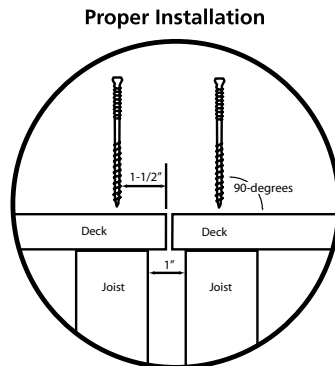

Figure h

Clean, perfectly straight lines of fasteners look better than wobbly lines. Use white chalk, straight boards or string lines as templates for straight lines.

### Fastening Boards

Veranda TD decking requires two fasteners at every joist location (Figure i).

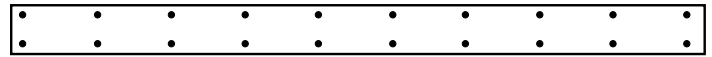

Figure i

### Fascia Installation

Fascia is intended as a non-structural covering for rim joists, risers and stringers. Screws should be installed at a maximum 12" interval, with three screws across the face at each interval (Figure j). Do not over-tighten screws as buckling may result. Install with 1/8" spacing between the edges and ends in temperatures above 50° F (10° C). Leave 3/16" space between edges and ends in temperatures below 50° F (10° C).

#### Proper Fascia Installation

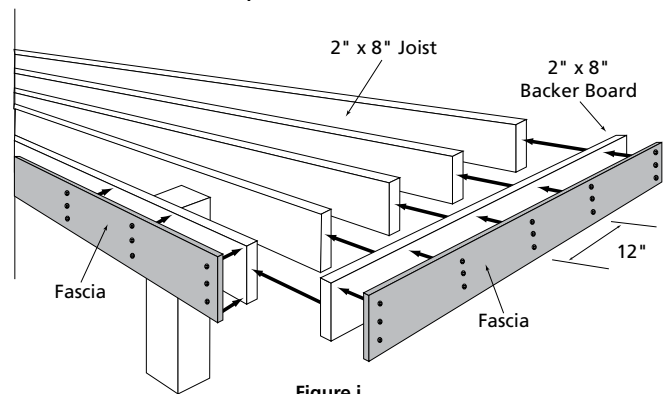

Figure j

### Ventilation

Do not install decking directly to a solid surface. Make sure there is adequate and unobstructed air flow under the deck to prevent excessive water absorption. Improve drainage or grade flat areas where standing water may gather. A minimum of 6" of continuous net free area under the deck surface is required for adequate ventilation on all decking so air can circulate between adjacent members to promote drainage and drying.

### Fire and Unusual Heat Sources

Composite decking will retain heat when exposed to direct or reflective sunlight. Exercise caution if walking barefoot as footwear may be required. Fire and unusual sources of heat and heat build-up can possibly damage Veranda TD decking surfaces. Examples would include fire, reflected light from different types of glass (ex. low-e glass), fire features and under-deck waterproofing installations that do not provide the 6" of un-obstructive net free ventilation.

- Low-E Glass/Reflected Heat**

Low-emissivity glass is designed to prevent heat gain inside the house by reflecting sunlight outward. This reflective property can result in excessive heat built on the surface of Veranda TD decking. The properties that Low-E glass employs to prevent passive heat gain within a structure can

result in unusual heat build-up on exterior surfaces.

When the sunlight is reflected and concentrated it can harm a range of building materials that include doors, windows, siding, trim and decking. Damage caused to these products can include melting, sagging, warping discoloration, increased expansion and contraction and accelerated weathering.

If you have questions on how to reduce this risk, contact the manufacturer of the product which contains the Low-E glass for suggestions on how to reduce or eliminate the reflected heat.

- **Under-deck waterproofing systems**

Under-Deck waterproofing systems, properly installed, can provide additional living or storage space. Improper installations are those that restrict air flow and result in build-up of heat and/or humidity which can result in unwanted consequences.

Contact the manufacturer of the specific Under-Deck Waterproofing System for installations instruction to ensure required 6" of un-obstructive net-free ventilation are achieved of Veranda TD decking. If already installed, seek methods to achieve the ventilation requirement.

- **Fire Features/Firepits**

Fire features and fire pits are increasingly popular in outdoor living environments. Fire can damage many building products including Veranda TD decking. Improperly installed fire features and fire pits can cause damage to the surface of Veranda TD decking via direct exposure to the flame or excessive radiated heat.

Proper caution should be taken when designing, installing and using these features to ensure damage does not result.

## **Static**

Dry and windy environments may create a temporary condition of static electricity, which will vary depending on climate and age of deck.

## **Important Ladder Usage Safety Instructions**

When using a ladder on composite decking, it is mandatory to lay down a sheet of plywood over the deck surface to disperse the load of the ladder's feet to nearby underlying joists. When doing this, drill fasteners downward through the top of the plywood sheet to keep it from slipping. Position these fasteners so they adequately protrude and rest firmly in the gaps between your deck boards. This will avoid leaving holes in your decking once the plywood sheet is removed. Be sure to always follow the ladder manufacturer's instructions & safety tips.